

GRF 5

Mobile Filtration Unit - 5 / 10 gpm



Description

Mobile filtration units

GRF 5 mobile filtration units are cost effective and efficient in transferring or conditioning fluid in hydraulic reservoirs that includes ICM 2.0 or ICM 4.0 contamination monitor and auto-shut down control when cleanliness targets are achieved.

Portable filtration unit with LMP211 cartridge style discharge filter assembly with a wide selection of filter media including water removal with optional ICM 2.0 or ICM 4.0 contamination monitor.

Applications

- Oil transfer from bulk drums to tank
- Reservoir clean-up

> Features & Benefits

- 1 HP, 115 VAC, 1- Phase TEFC motor with motor start/stop, cord and plug
- Rugged 5 gpm or 10 gpm gear pump with integral relief valve
- 10 ft. wire reinforced clear suction and discharge hoses with stainless steel wands
- Mounted inline contamination monitoring (ICM) unit to measure fluid cleanliness
- Heavy duty hand truck with pneumatic tires, powder coated in MP Filtri Blue
- 2 pc 4 ft. stainless steel wands
- Wand Storage brackets with accommodation to contain excess in drip pan
- 25 ft. electrical cord with end plug, includes cord storage hook
- On-board sealed on/off switch

Suction Side

- 1 pc CSG100M90A - 90 µm wire mesh element

Discharge Side

- 1 pc LMP2112 housing with 50 psi bypass
- Choice of 1, 3, 6, 10, 25 µm elements available

ICM

- 8 channel contamination measurement
- International standard formats ISO 4406, NAS 1638 AS 4059E and ISO 11218
- Data logging and 4000 test result memory
- Mineral oil fluid compatibility
- Optional water/temperature sensor
- Optional 6-key keypad and 128 x 64 LCD back-lit display
- Optional relays
- CMP View software included

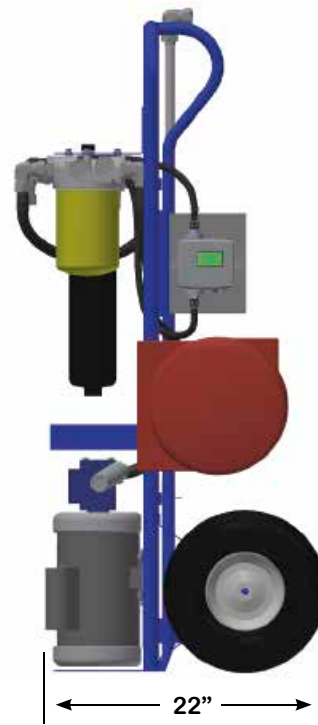
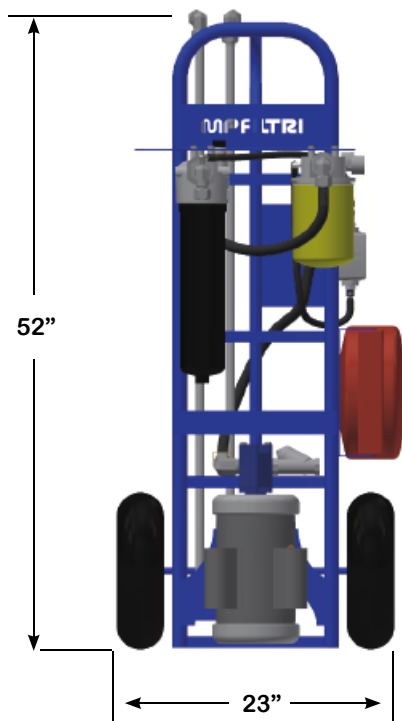
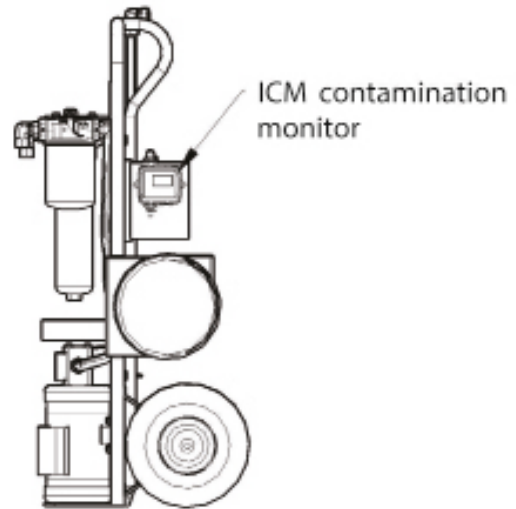
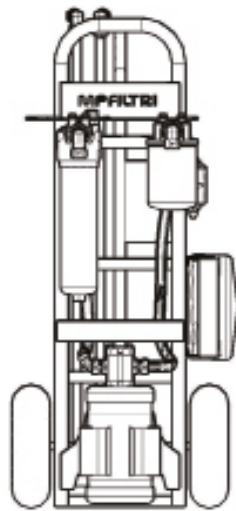

GRF 5

Designation & Ordering code

MOBILE FILTRATION GRF 5

Series	Example:	GRF5	10	2	Y	A	A03	ICMW	M	K	U	2.0	P01
GRF5													
Size													
05	5 gpm												
10	10 gpm												
Type													
2	LMP2112 assembly on discharge												
Suction side spin-on element													
Y	250 Y Strainer												
Seals													
A	Buna												
Discharge side cartridge element													
A01	CU2102A01ANP01												
A03	CU2102A03ANP01												
A06	CU2102A06ANP01												
A10	CU2102A10ANP01												
A25	CU2102A25ANP01												
WA25	CU2102WA25ANP01												
ICM Water / Temperature sensor													
ICMO	Without water / temperature sensor												
ICMW	With water / temperature sensor												
Fluid Compatibility													
M	Mineral Oil												
Keypad													
K	With 6-keypad with display												
Relays													
R	With relays/external alarms												
Design Reference													
2.0	ICM 2.0												
4.0	ICM 4.0 with integral WiFi												
Execution													
P01 MP Filtri standard													
Pxx Customize													

Note: Consult factory for options not listed

MP Filtri reserves the right to make improvements in design, product features and specifications at anytime without notice.