

# OIL & GAS



PASSION  PERFORM



## HYDRAULIC FILTRATION



Designing an effective filtration system requires a precise evaluation of its specific features, including: sensitivity of the individual components, degree and type of contamination, circuit pressure,

flow rate, environmental conditions, fluid used and intervention cycles with a guarantee of a longer life of the machines than expected.

### STAINLESS STEEL HIGH PRESSURE FILTERS

Stainless steel construction ensures peak protection when operating in corrosive environments or aggressive fluids. High pressure stainless steel filters are used to protect individual valves or the entire hydraulic circuit from contamination.



### FILTERS FOR POTENTIALLY EXPLOSIVE ATMOSPHERE

Standard ATEX Directive 2014/34/EU and UK Regulation S.I. 2016 No. 1107 (as amended). There are two different markings, defined by the type of sealing material that determine the maximum operating temperature.

#### THE ATEX CERTIFIED MP FILTRI PRODUCTS ARE THE FOLLOWING

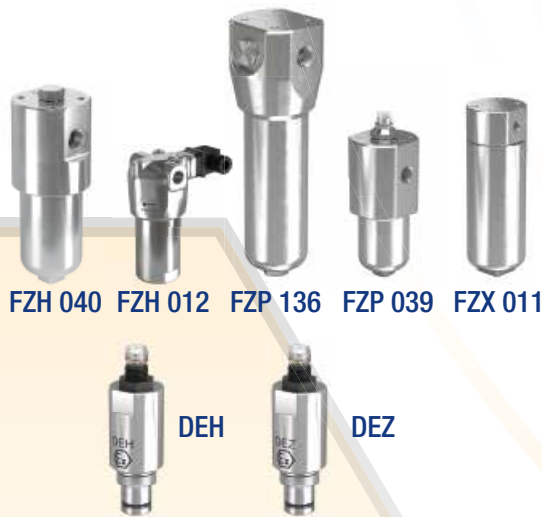

Filter with NBR seal in configuration **zerospark+**



II 3G Ex h IIC T6 Gc X  
II 3D Ex h IIIC T85°C Dc X  
 $T_{amb} : -15^{\circ}\text{C} \div +80^{\circ}\text{C}$ ,  $T_{max\ fluid} +80^{\circ}\text{C}$

Filter with EPDM / FPM / MFQ seal in configuration **zerospark+**



II 3G Ex h IIC T6... T4 Gc X  
II 3D Ex h IIIC T85°C...T115°C Dc X  
 $T_{amb} : -15^{\circ}\text{C} \div +110^{\circ}\text{C}$ ,  $T_{max\ fluid} +110^{\circ}\text{C}$

### FILTER ELEMENTS

DIFFERENT OPTIONS OF FILTER ELEMENTS WITH THE MYCLEAN AND ZEROSPARK® CONCEPTS

Wide range of filter elements in various filtration grades for all MP Filtri filters and as market interchanges.



THE **X** CONCEPT FOR OUR FILTERS

**zerospark+**  
THE ANTI-STATIC FILTERS

THE **Z** ANTISTATIC CONCEPT FOR OUR FILTERS



THE ANTI-STATIC FILTERS

**zerospark+**

Zerospark® is a specialised solution designed to solve the problem of electrostatic discharge inside hydraulic filters. Caused by the electrical charge build-up due to the passage of oil through the filters, this can result in damage to filter elements, oils and circuit components. It can even cause fire hazards in environments where flammable materials are present.

## TANK ACCESSORIES

The complete range of tank accessories for hydraulic circuits comprises breather filters, filler and breather filters, filler caps, visual and electrical level indicators, pressure gauges selectors, flanges for fixing the oil tubes on the tank cover and inspection doors. Filler and breather filters have a dual function at the

tank inlet in the filtration of the incoming air and the pre-filtration of the fluid through the basket, in order to prevent the entry of foreign bodies during the filling or refilling operations.



TA 70    SAW    TAP 90    LVA 20    LVK    STRC    RLG/LEN

## POWER TRANSMISSION



### COUPLINGS

Drive couplings provide the means by which power is transmitted from the electric motor to the hydraulic pump.



SGE series  
AKG series



II 2G Ex h IIC T6...T4 Gb  
II 2D Ex h IIIC T85°C...T135°C Db

Installation zone: **zone 1 / 21**    Dust group: **IIIC**

Gas group: **IIC**

Ambient temperature: **-30C° ÷ +120°C**



### BELL-HOUSING

Bell-Housings are used as connecting elements between IEC electric motors and a wide range of hydraulic pumps available on the international market.



### ACCESSORIES

Our accessories line completes the range, adding value and features to the motor pump unit.

## CONTAMINATION CONTROL SOLUTIONS

MP Filtri designs and manufactures a complete range of contamination control solutions aimed at increasing the life and the productivity of the hydraulic circuits. The technology developed by our Contamination Monitoring Products division allows preventive and predictive maintenance, guaranteeing

maximum continuity of operation, a longer life cycle of the components and a relative reduction in costs. A complete solution that combines highly functional and energy-efficient systems with a wide range of after-sales services.

### CONTAMINATION MONITORING PRODUCTS



**LPA3**  
Portable  
Light Extinction  
Particle Analyser

### IN-LINE CONTAMINATION MONITORS



**ICM 2.0**  
In-Line  
Contamination  
Monitor

**ICM K 2.0 AZZ**  
In-line  
Contamination  
Monitor  
suitable for  
hazardous areas



### MOBILE FILTRATION UNITS



**UFM 015**  
15 l/min  
(3.96 gpm)

**UFM 051**  
50 l/min  
(13.20 gpm)

**UFM 181**  
90 l/min / 180 l/min  
(23.77 gpm / 47.55 gpm)

# WORLDWIDE NETWORK

CANADA ♦ CHINA ♦ FRANCE ♦ GERMANY ♦ INDIA ♦ SINGAPORE  
UNITED ARAB EMIRATES ♦ UNITED KINGDOM ♦ USA

A world map in shades of blue with several yellow location markers. A prominent marker in Italy is labeled 'HQ ITALY' and has a white signal icon above it. Other markers are located in North America, Europe, the Middle East, and Asia.

HQ  
ITALY



PASSION  PERFORM

in   



[mpfiltri.com](http://mpfiltri.com)

Scan or click me!

MP Filtri reserves the right to make modifications to the models and versions of the described products at any time for both technical and/or commercial reasons. For updated information please visit our website: [www.mpfiltri.com](http://www.mpfiltri.com). The colors and the pictures of the products are purely indicative. Any reproduction, partial or total, of this document is strictly forbidden. All rights are strictly reserved.

MF002000188  
US - 2025.03